

PoPデバイスの評価/解析どうしてですか？

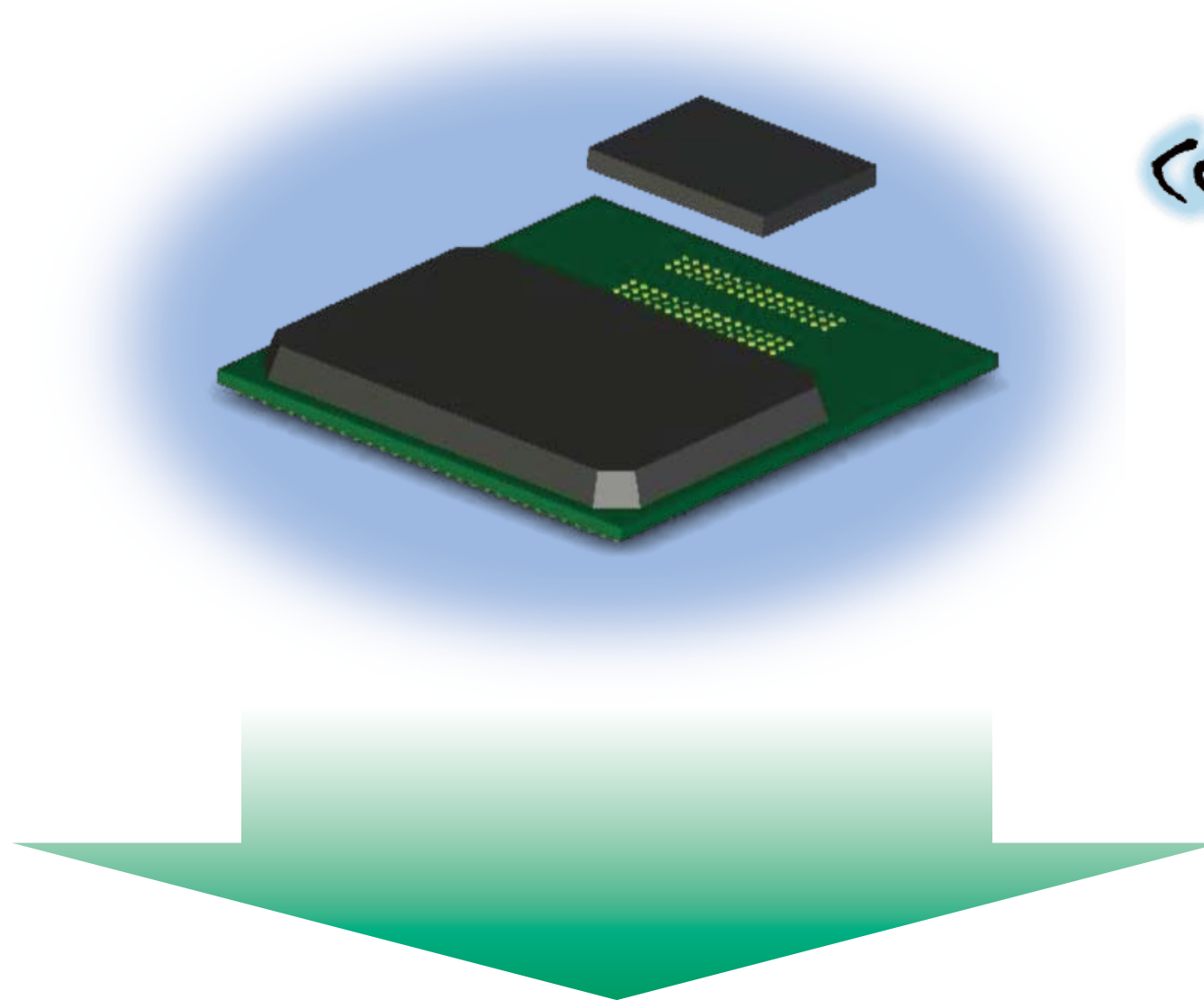

SERにおまかせ!!

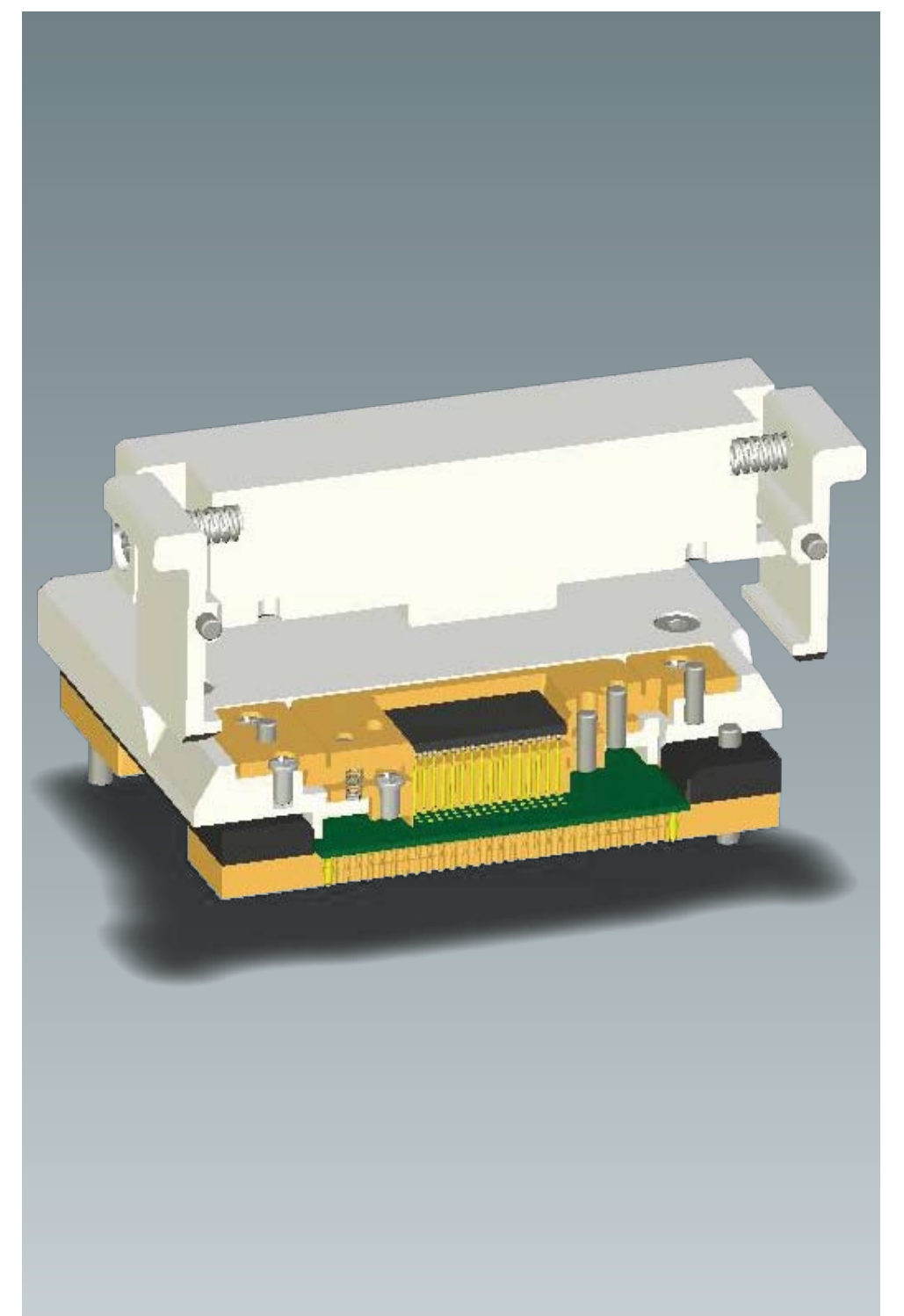
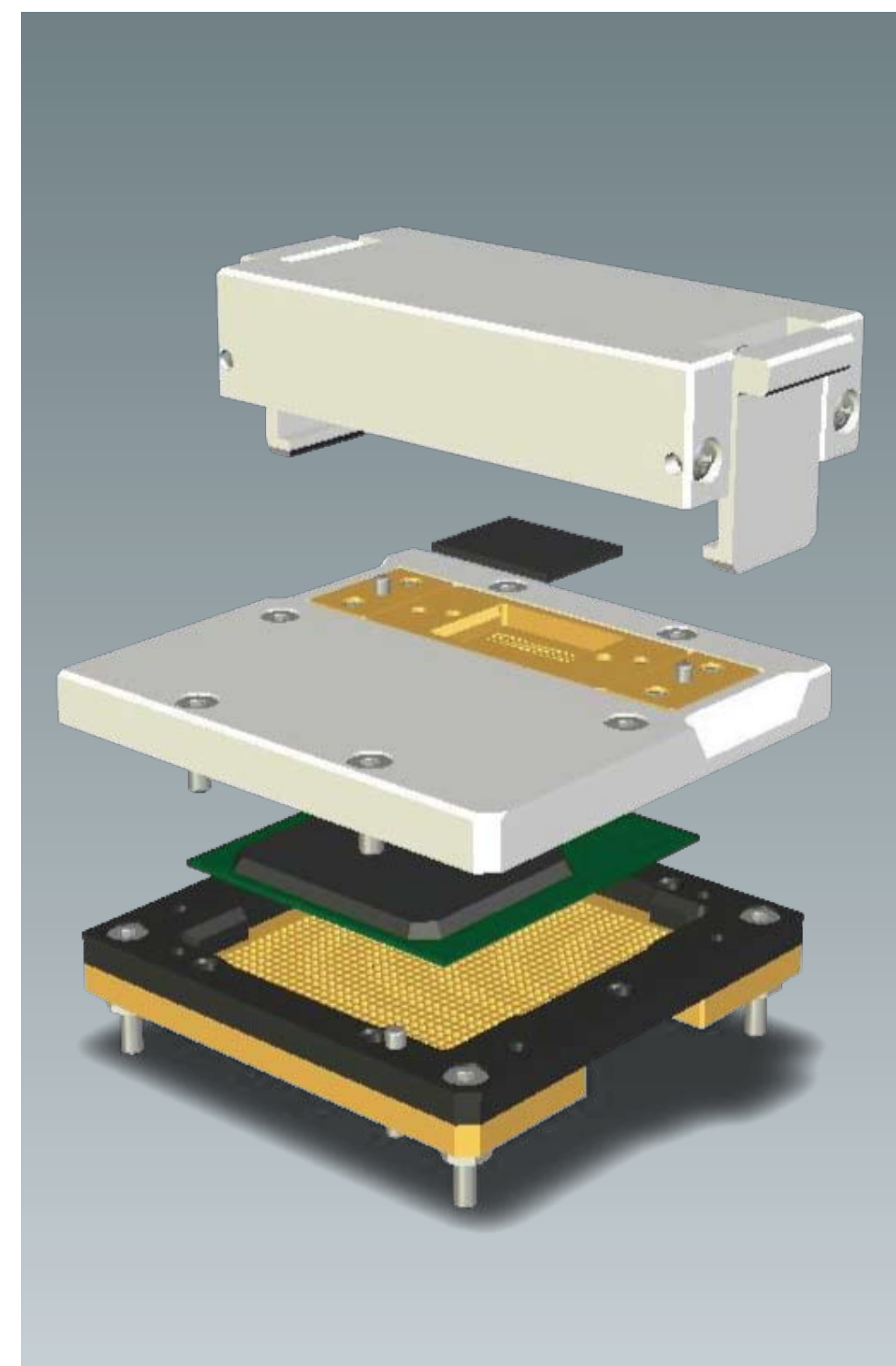
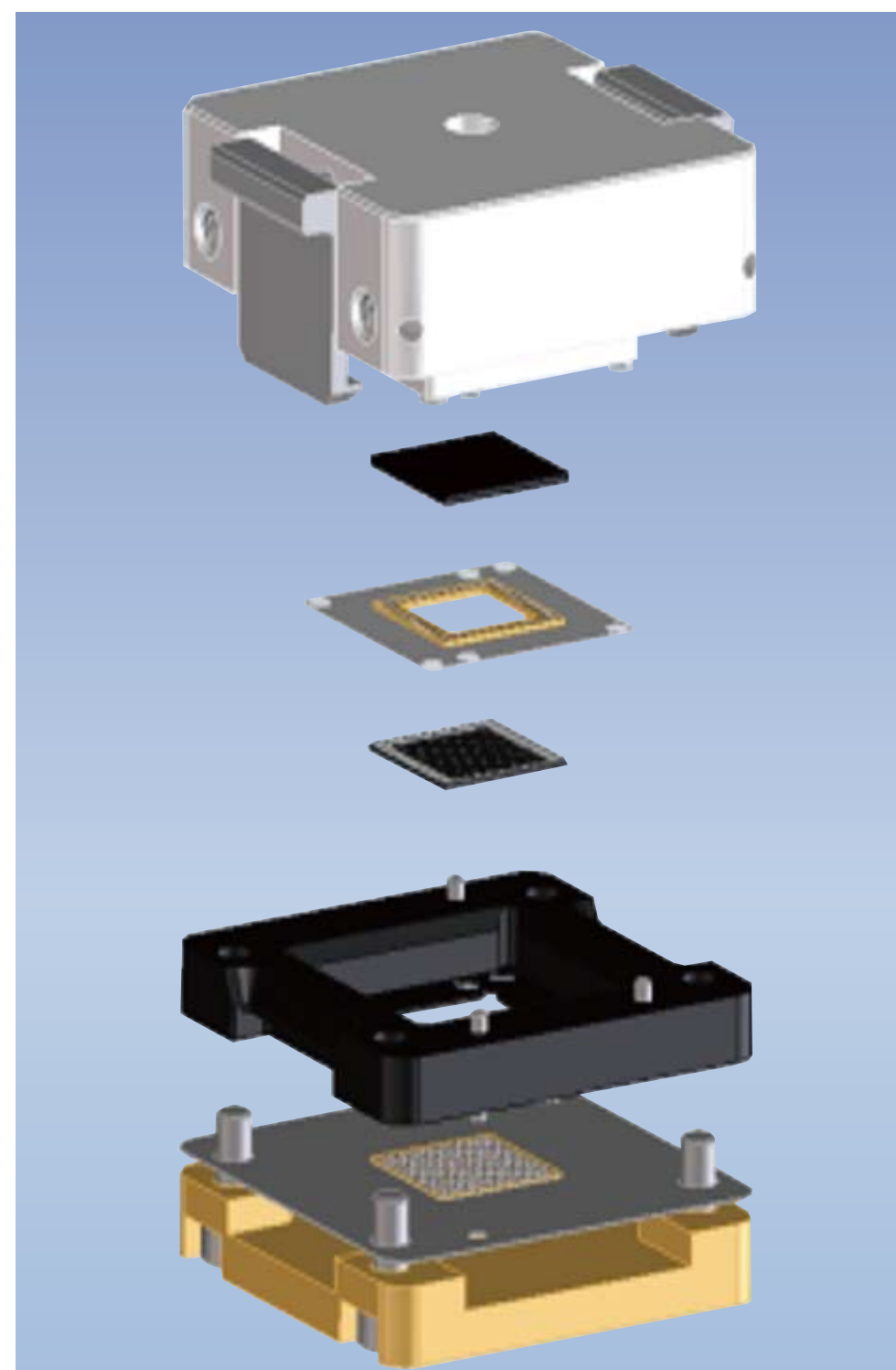
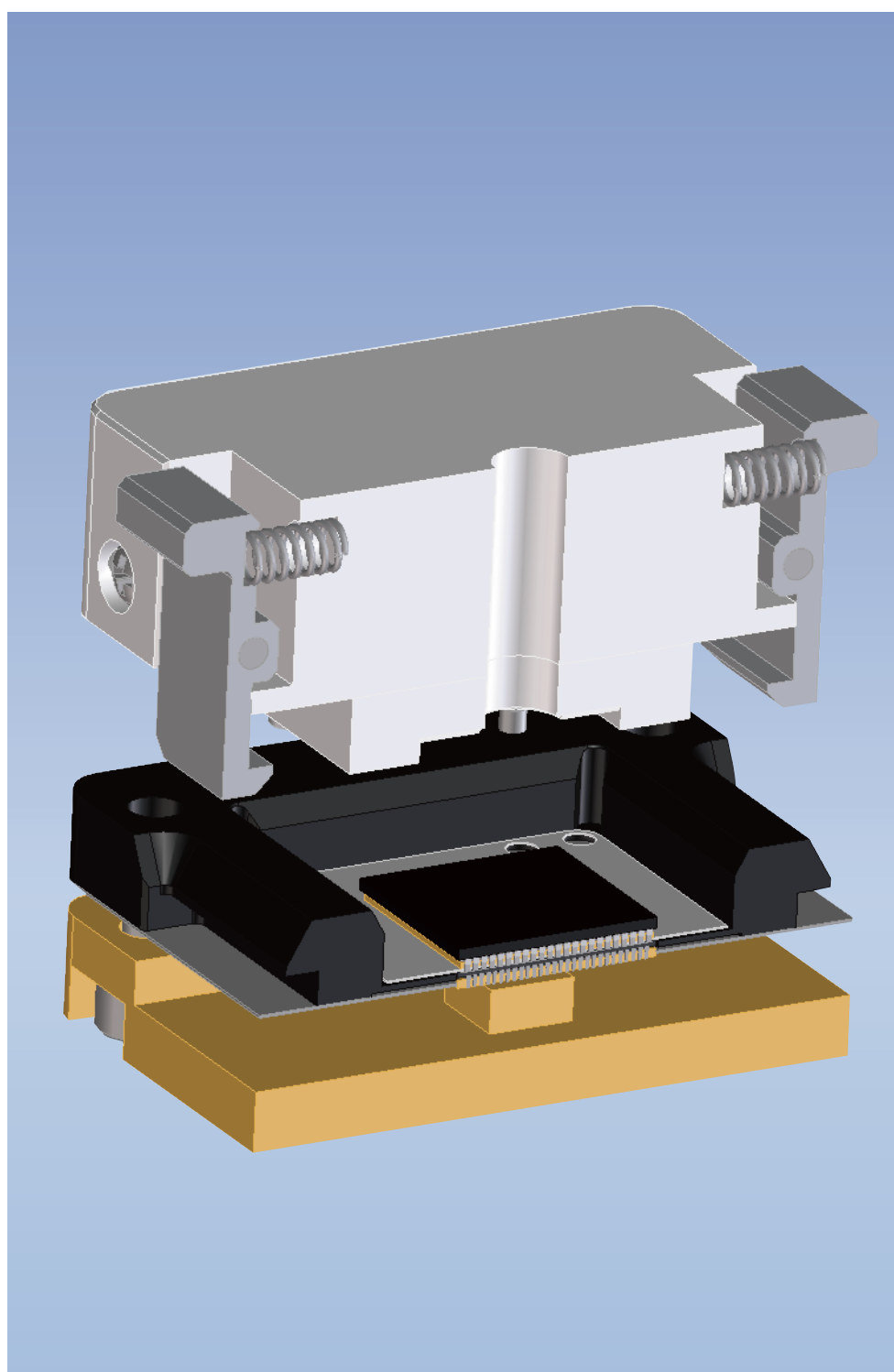

スタッキング型ソケットで解決します!!



SER New Solution Stacking Sockets for Package on Package

製品の主な特長

- PoP/SiP/MCMなどモジュール型IC及び基板のテストが1ソケットで可能。
Variable application use for PoP/SiP/MCM module type IC and for circuit board test.
- Mainデバイス+メモリ(DDRなど)を組み合わせた評価/解析に最適。
Combinational use for evaluation/analysis of main device + memory like DDR.
- 狭ピッチ(~0.3mm)、同軸プローブ構造、超多ピン配列への応用も可能。
Best for narrow pitch matrix like 0.3mm, coaxial probe and ultranumber of contacts.