

Complete $Z_0=50\Omega$ Coaxial Spring Probe IC Socket **RF-C SOCKET**

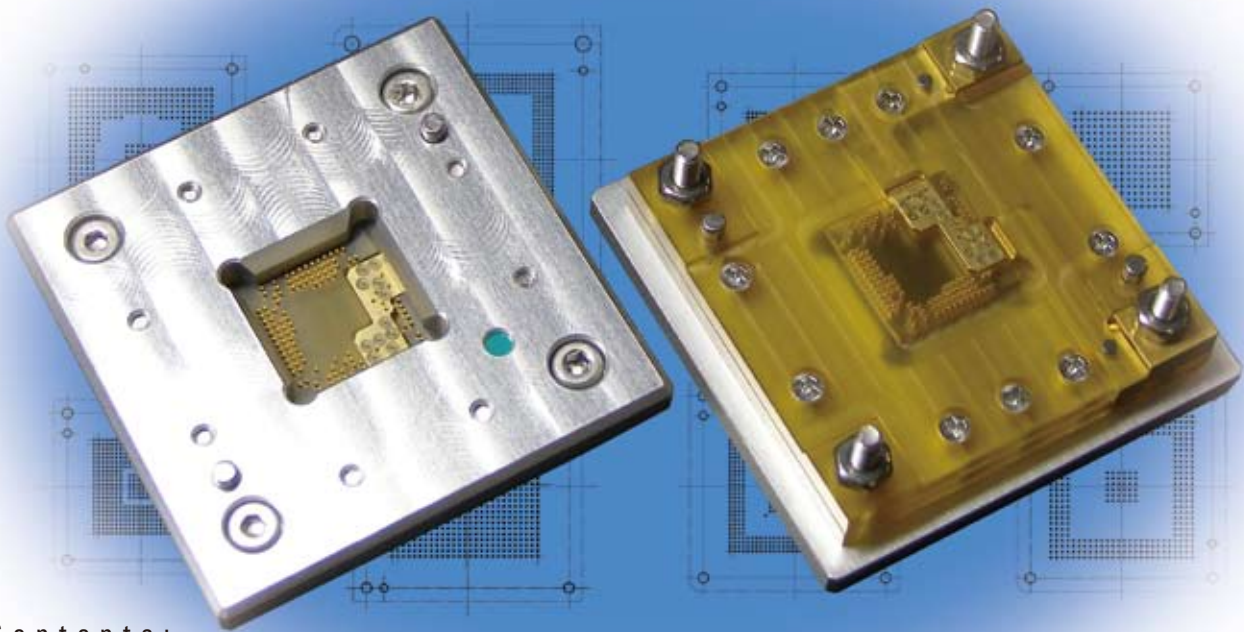

Contents :

1. Product Description
2. Application Information
3. Ordering Information
4. Bit 2008 Engineering Note
5. Equivalent Circuit Model

ELECTRONICS PARTS



CUSTOMIZED
SOCKETS & CONNECTORS

S.E.R. CORPORATION

www.ser.co.jp E-mail ser@ser.co.jp

Coaxial Spring Probe IC Socket Complete $Z_0=50\Omega$

1. Product Description

SER's RF-C Socket Family shown on Photo.1 "Z₀=50Ω Complete Coaxial Spring Probe IC Socket" has superior performance on 20GHz or over at Super High Frequency (SHF) bandwidth for LSI Evaluation, Inspection and Testing. The Socket base is composed of copper alloy partially or whole. This structure equalizes to zero ohm connection between PCB GND, Socket GND and IC's GND. It is also best way for keeping higher speed coaxial signal GND stable. The coaxial spring probe is complete Z₀=50Ω. It is brought by careful design on any portion of coaxial probe component to be 50Ω characteristic impedance by adjusting dimension and choosing dielectric for coaxial. The socket has achieved high frequency performance 20GHz or over.

RF-C Socket Family is available for the contact pitch of 0.5, 0.8, 1.00, and 1.27mm on IC packages like BGA, LGA, CSP and QFN. To achieve a high performance in SHF bandwidth and ultra-high speed, IC socket contacts and probes must be identified for each LSI lead function and necessity of classify for High speed, Normal speed, GND, Power and etc. individually. "Package Drawing and Pin Assignments" must be needed on standardized RF-C Socket Family.

The Socket sizes are available to choose from 28×28, 33×33, 39×39, 47×47, 60×60mm for any IC package sizes up to 45×45mm.

RF-C Socket Family is also suitable for the application like High Speed Communication, Image Processor LSI evaluation or inspection and high performance handler testing on its performance of high endurance 100K cycle and frequency 20GHz or over. The socket is able to use for multiple application concept and evaluation like A/D, D/A converter and Hybrid Module which must be required more stable GND for analog circuit and high frequency circuits. "Z₀=50Ω Complete Coaxial and stable GND" is complex and integrate technologies on managing RF signal and GND, and can be used for many type of application widely as like for B-to-B connectors and complex organize connectors.

Product Features :

- Complete Z₀=50Ω coaxial spring probes.
- Equated GND for PCB, Socket and IC.
- Super High Frequency Transmission Performance 20GHz/@ -1dB.
- 0.5, 0.8, 1.0 and 1.27mm coaxial contact pitch.
- Partial Socket GND organization is available.
- Power and other signal contacts are individually distinguished.
- Semi standard and full customized sockets are available.

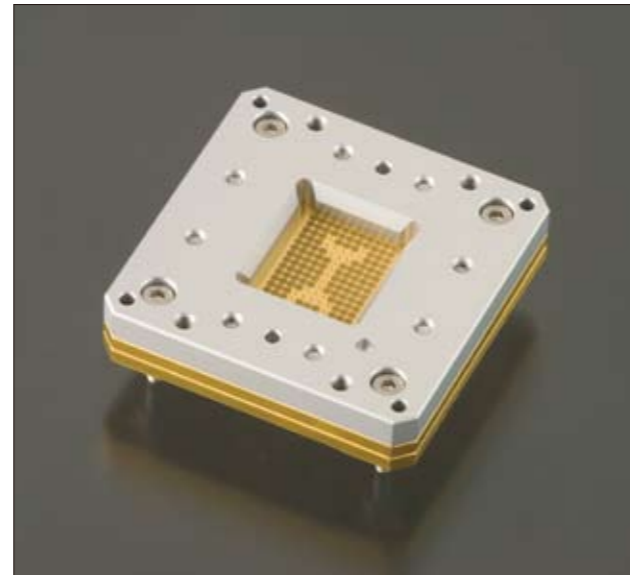

Photo. 1 RF-C Socket Family, Complete Z₀=50Ω Coaxial Spring Probe IC Socket

Product Applications :

- BGA, LGA, CSP, QFN IC socket.
- IC sockets for evaluation, debug and inspection.
- Handler Test Socket for IC production line.
- IC sockets for A/D and D/A converters.
- For Hybrid-IC and Module type connector.
- B to B connector.
- Production IC sockets.
- Socket jig for frequency performance testing.

2. Application Information

Manufacture process and packaging technologies on semiconductor industry have rapidly been advanced. LSI characteristics especially operation speed and frequency is exceeding higher and higher than SHF band width. And it must be followed on the engineering of PCB industry and the engineering of conventional IC sockets and connectors by exceeding view point of high frequency circuit board technology. The RF-C Socket Family with higher than 20GHz frequency characteristic has made it possible to meet with LSI performance.

(1) Concept of Complete Coaxial Probe for Realizing High Frequency Characteristic

In order to design and realize IC socket for super high frequency (SHF) performance, it is necessary to organize and position complete coaxial probes, GND probes, Power Supply probes, and other Signal probes. (Refer to Photo.2 & Fig.1)

The high frequency circuit board is designed to eliminate the distortion of the wave form and inaction for transmitting the mismatching and to retain characteristic impedance 50Ω on distribution of circuit patterning, as much as possible. It must be avoided mismatching element on circuit patterning or extension of circuit even the IC socket mounted on PCB.

Concept of RF-C Socket is to structure a complete coaxial Z₀=50Ω probe contact to achieve a characteristic impedance Z₀=50Ω on any position of the probe connection length such as including lower plunger, barrel and upper plunger between PCB land and IC terminal. This coaxial probe contact can achieve Z₀=50Ω at any portion on contact length by composed two type of dielectrics and calculated coaxial core diameter of probe. (Refer to Fig.1 & (5) for detail)

To complete the design of IC socket, it needs to identify LSI package drawing with function assignment terminal list and table to distinguish metal base use and not for locating of coaxial probe, GND and regular signal terminal position.

(2) Assignment of GND Terminals and Grounded Socket Base

Complete Coaxial Probe is composed of coaxial GND sleeve hole penetrated on metal socket base (plated copper alloy) with high

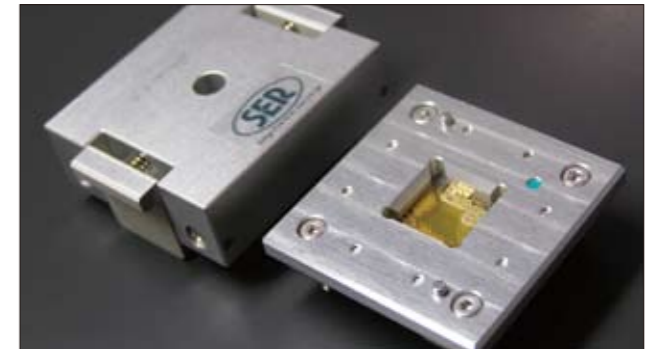

Photo. 2 Complete Z₀=50Ω Coaxial Spring Probe IC Socket

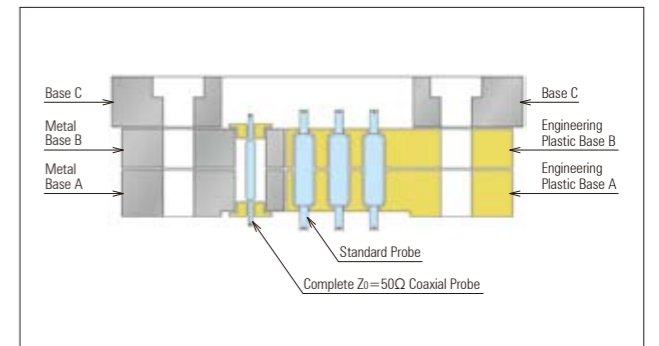

Fig. 1 Complete Z₀=50Ω Coaxial Probe IC Socket

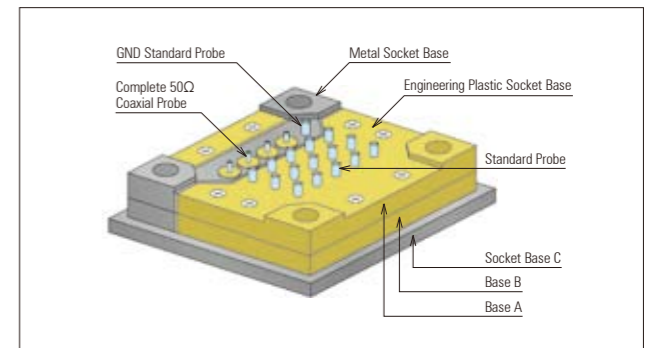

Fig. 2-1 Bottom View Complete Z₀=50Ω Coaxial Socket

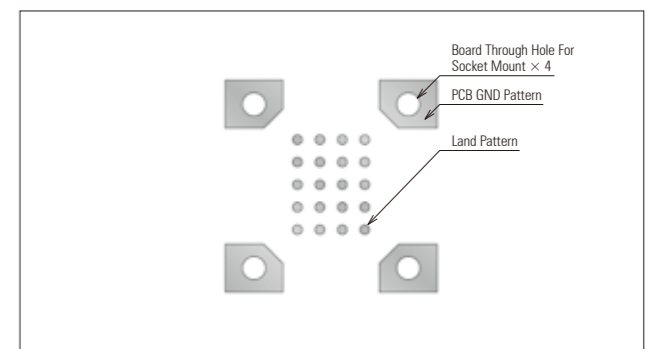

Fig. 2-2 RF-C Socket Family Bottom View

frequency coaxial core probe line. And the probes for GND lead and land are directly embedded into metal socket base. On mounting a socket to the PCB, the corner edges of metal socket base are fixed with PCB GND through-holes to unify GND by screws. Consequently, LSI GND terminals are connected with socket GND probes as unified with the PCB GND. (Refer to Fig. 2-1, Bottom View of RF-C Socket Family)

(3) GND Pattern Locating and High Frequency Signal Patterning on PCB

PCB GND must not only be distributed to IC GND terminal location, but portion of IC socket mounting corners constructed by metal base must be also allocated GND pattern for getting stable GND organization. (Refer to Fig. 2-2, Foot Print Pattern)

The high frequency signal lines on circuit board are wired to just under the land of complete coaxial probe terminal by $Z_0=50\Omega$ characteristic impedance. On a case of wiring that on the surface of board, there is some possibility of changing the characteristic impedance under wired part due to IC socket metal base is electrical GND.

To solve this issue, for example, it must be wired throughout the middle of board layer to the coaxial contact land or adjusting the socket GND base wiring pattern width and then connect to the coaxial contact land by $Z_0=50\Omega$.

(4) Power Supply Terminal and Other Signal Terminals

The coaxial terminals for high frequency signals and its peripheral GND terminals must be treated separately against power supply terminal and the other signal terminals. The metal part of socket base should be smaller as possible and the other base part is structured by high polymer plastic to mount standard type probes for power supply and other signal probes. (non coaxial) It is needed to structure gains sufficient electric current for power terminal per probe and cost efficient by using non-coaxial probes for other normal terminals. (Refer to Fig. 2-1, RF-C Socket Family)

On a case of fine pitch coaxial, the core of coaxial probe diameter is required to be thinner. But it reflects to probe current capacity being difficult to gain sufficient electric current for a per probe terminal of LSI as to use coaxial probe terminal for power supply terminal. It is another reason why high polymer plastic socket base is used for taking good probe distribution balance.

(5) $Z_0=50\Omega$ Complete Coaxial Probe Structure

Structure of $Z_0=50\Omega$ Complete Coaxial Probe uses a spring probe as a coaxial core and characteristic impedance Z_0 equal to 50Ω at any portion of coaxial probe length. As shown on Fig. 3, coaxial core diameters are proper dimension of each contact pitches of 0.50, 0.80, 1.00 and 1.27mm. Coaxial GND sleeves are opened through holes in metal socket base. The equalized value Z_0 of the plunger and barrel portion on probe are achieved by precisely adjusting the diameter and use of different dielectrics. The ring shape dielectrics over a probe plunger on a metal base socket are held by pressing fit as shown on Fig. 3.

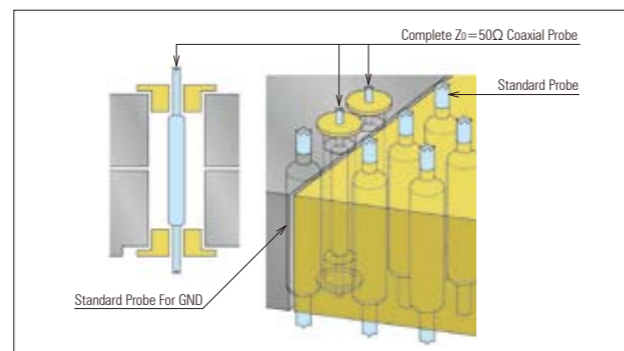

Fig. 3 Complete $Z_0=50\Omega$ Coaxial Probe

(6) Spring Probe and its Characteristics

Shown on Fig. 4-1, spring probe is used as coaxial core, for example SER P/N: MD0102-00 for 1.0mm pitch and SER P/N: MD0138-00 for 0.5mm pitch. It is coaxial core for high frequency signal line and has 15GHz " $S_{21}@-1dB$ " of frequency characteristic. Fig. 4-2 graph shows

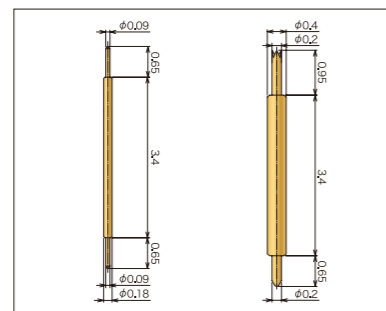

Fig. 4-1 Coaxial Core Spring Probe

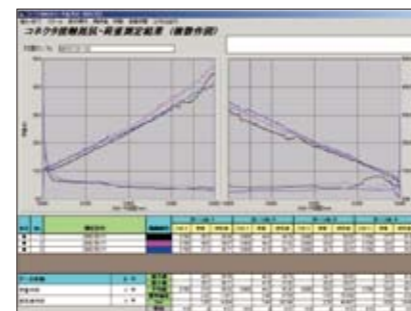

Fig. 4-2 Performance Curve

characteristic of pressure and contact resistance "Performance Curve" for double side contact probe. X-axis shows travel distance of plunger being pressed and Y-axis shows the variation of contact resistance and spring force against the plunger moving distance.

(7) Mounting IC Socket on Printed Circuit Board

To fix the IC socket on PCB, it must be fixed by screw and nut through mounting hole of 4 corners of socket mount holes and 4 of PCB mount holes as shown on Fig. 5. At this time, coaxial contact and other terminals are contacting PCB lands as pre-load condition. Dielectric ring of coaxial area is the stand-off and protect for short-circuit of PCB and the socket base. As Fig. 5 shows, the probe GND contact with the PCB GND and Socket GND allows the IC GND to become quite stable electrical GND.

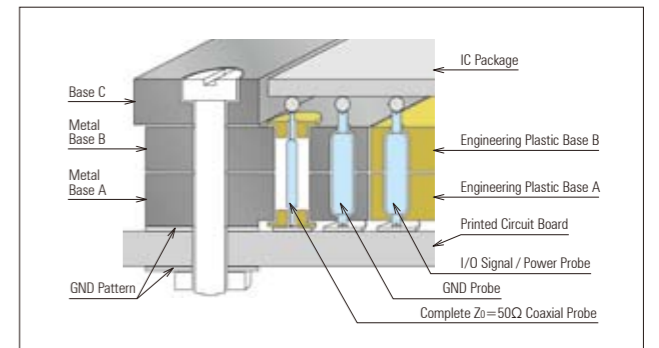

Fig. 5 Mounting Coaxial Probe Socket on Printed Circuit Board

(8) High Frequency Characteristic

$Z_0=50\Omega$ Complete coaxial probe has a performance exceeded high frequency of 18GHz "Blue line : gain @-1dB" on S_{21} transmission performance according to loop measurement. MD0102-00 used for a coaxial core has a performance on non-coaxial condition "Loop measurement" is higher than 15GHz "Red line : gain @-1dB" shown on Fig. 6.

Please refer to the technical document 4 & 5 for detail described on this data sheet.

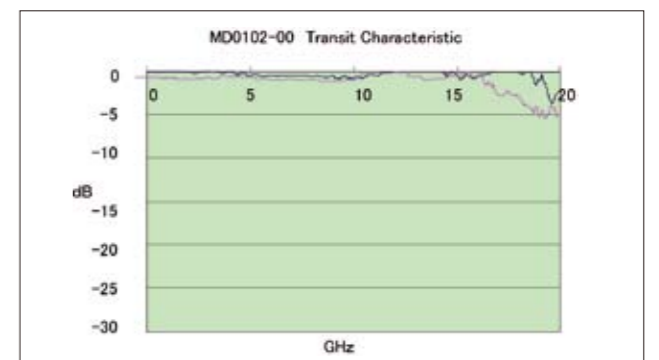

Fig. 6 Example of transit characteristics compared with coaxial and non-coaxial

(9) Hold IC and Socket Cap

Caps for Complete $Z_0=50\Omega$ Coaxial Probe IC Socket are selectable upon the requirement of applications. During the process of manufacturing IC and using the handler for its final test, socket caps are not required. However, the caps needed for test conditioning and the other purpose like ASIC, FPGA and LSI development and evaluation tests, the Screw Cap is recommended due to the rarity of changing the IC. In case changing IC package would be so frequent, One Touch S Cap and Handle Type Cap are also easily available to change and load LSI to the socket shown on Fig. 7. It is necessary for socket design to know IC package size, thickness and terminal in detail. Please contact and exchange any information with our sales staff.



Fig. 7 Screw S Cap & One Touch S Cap

(10) Selection of IC Sockets to Fit for Package and Dimensions of PCB Foot Prints Design

RF-C Socket can be selected and assigned for socket dimension, mounting method and cap selection for IC package, which customers are supposed to use.

- 1 Specify lead terminal pitches of IC package, package dimension and pin assignments for the purpose of using IC package.
- 2 Refer to Table 1 about pitch dimension by depending on pin pitch. For example, package size is 15mm with 0.5mm pitch, shorter than 19mm Package Size on (1) 0.5mm pitch Table can be applied.
- 3 Fig. 8 is used for the most suitable Socket and Foot Print Dimensions with the use of IC Package. Based on the selected example of 2, size are as follows ; base socket size is "A=28×28mm", socket cavity mouth is "C=15.2mm (15.0+0.2mm Gap)". With contact pitch being "e=0.5mm", package lead size "E" and matrix pattern are the same with IC package pin assignments.
- 4 On PCB design to fix the socket, locate the pierced hole "1.85mm" with alignment key positions "G=16mm", "H=24mm", and locate also 2.3mm through hole for M2 screw which is used for socket mount hole location "B=24mm".
- 5 Customers can select socket cap among Figs. 9, 10, 11 and 12 despite IC package pitch or size. The caps like Figs. 9 and 10 are recommendable for cost efficient use, but long time and low number of IC package load usage. The type of Figs. 11 and 12 are very fit for easy and quick package changing use. Because of load press weight difficulty on large number lead contact like 1,000 over, it is recommended all other caps except Fig. 11 "One Touch S Cap".

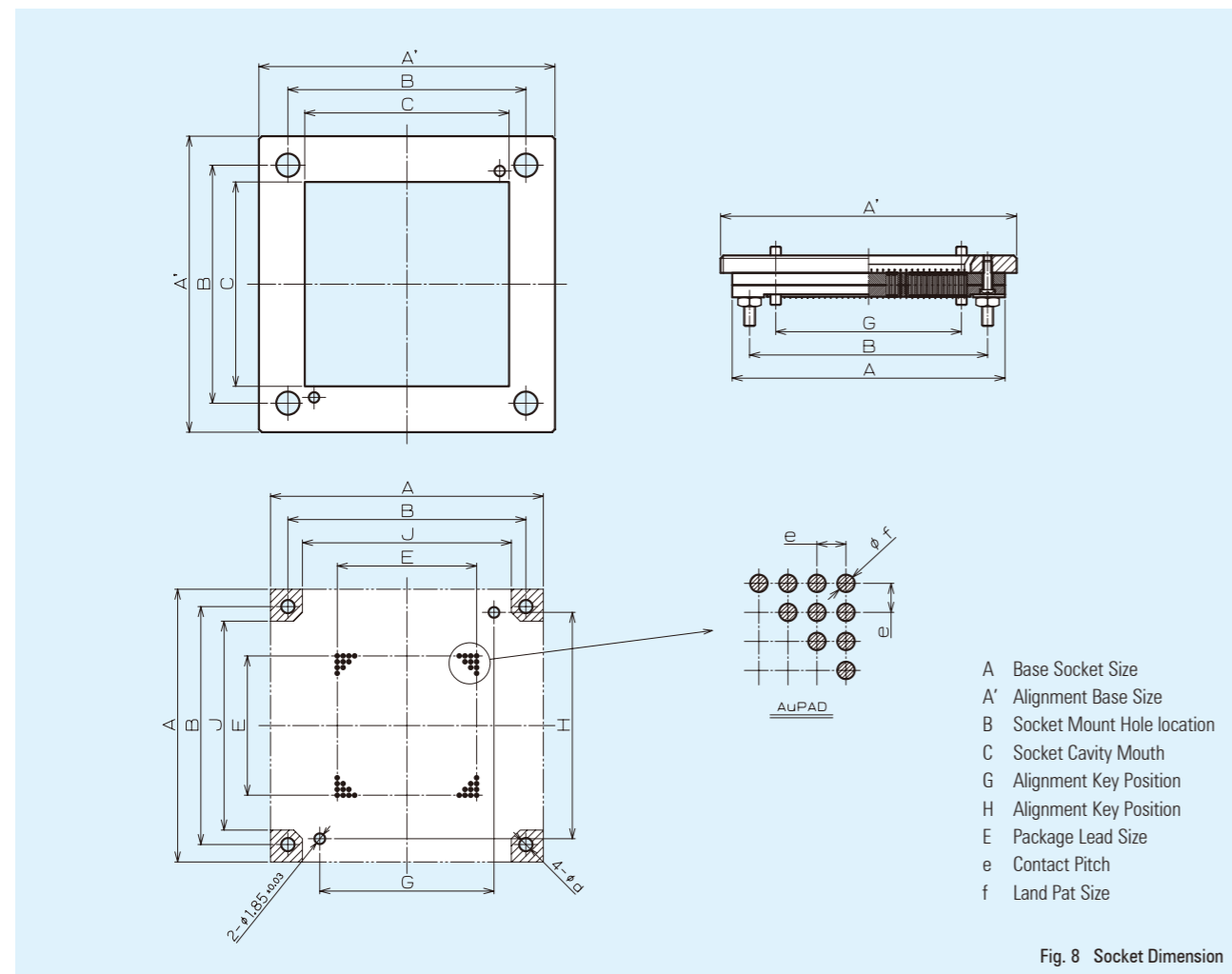

Fig. 9 Screw Cap



Fig. 10 Screw S Cap

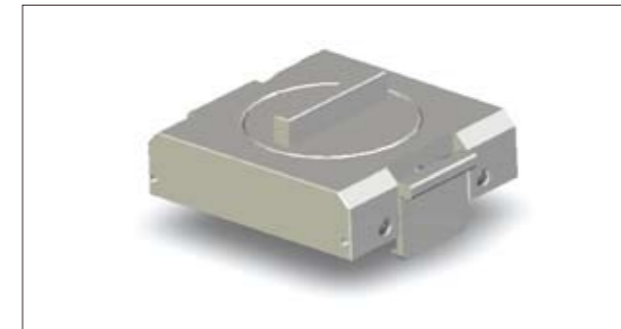

Fig. 11 One Touch S Cap

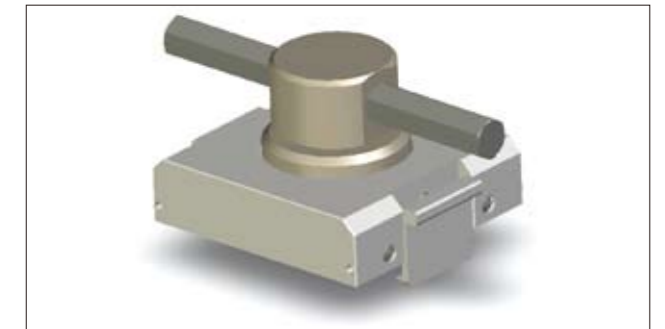

Fig. 12 Handle Cap

(1) 0.5mm Pitch

	Package Size	
	Up to 19mm	Up to 23mm
A	28	33
A'	32	37
B	24	29
C	MAX 19.2	MAX 23.2
E	MAX 17.5	MAX 21.5
G	16	20
H	24	29
J	19	24
e	0.5	
f	0.3+0.05/0	
d	4-φ2.3	

(3) 1.0mm Pitch

	Package Size		
	Up to 27mm	Up to 35mm	Up to 45mm
A	39	47	60
A'	43	51	66
B	33	41	52
C	MAX 27.2	MAX 35.2	MAX 45.2
E	MAX 25	MAX 32	MAX 43
G	24	32	40
H	33	41	52
J	28	36	45
e	1		
f	0.6+0.05/0		
d	4-φ2.3		4-φ3.2

(2) 0.8mm Pitch

	Package Size	
	Up to 19mm	Up to 23mm
A	28	33
A'	32	37
B	24	29
C	MAX 19.2	MAX 23.2
E	MAX 17.6	MAX 20.8
G	16	20
H	24	29
J	19	24
e	0.8	
f	0.4+0.05/0	
d	4-φ2.3	

(4) 1.27mm Pitch

	Package Size		
	Up to 27mm	Up to 35mm	Up to 45mm
A	39	47	60
A'	43	51	66
B	33	41	52
C	MAX 27.2	MAX 35.2	MAX 45.2
E	MAX 24.13	MAX 33.02	MAX 43.18
G	24	32	40
H	33	41	52
J	28	36	45
e	1.27		
f	0.6+0.1/0		
d	4-φ2.3		4-φ3.2

Table 1. Socket Dimensions by Pitch

3. Ordering Information

Please choose and assign the below ordering information when you place an order so that your requested part number will be formed.

C 05 C 256 - SS - 28 (- XXXX)

(Consult Factory)

Base Socket Size (mm) :
 28 33 39
 47 60 xx Custom

Cap Type : SS = Screw S Cap
 ST = One Touch S Cap
 S2 = Screw Cap
 SH = Handle Cap
 NC = No Cap

Number of Pins :
 64 78 100 144 256 356
 484 652 672 676 780 1,020
 1,156 1,508 1,760 Assign actual number

Package Type : B=BGA C=CSP L=LGA
 Q=QFN M=Module

Pitch (mm) : 05=0.50 08=0.80 10=1.00 12=1.27 XX=Mix

Socket Family Name : C= RF-C socket

Product type number assignment for RF-C socket family

Please refer to the numbering system above.

1. **Family Name** : C means RF-C socket Z₀=50Ω Complete Coaxial Probe Socket
2. **Pitch** : Assign the contact lead pitch on a package
3. **Package Type** : Choose and assign package lead type or package category.
4. **Number of Pins** : Assign actual contact lead number of the package.
5. **Cap Type** : Choose retainer cap type for package hold in a socket cavity.
6. **Socket Size** : Choose related Base Socket size from IC package size.
(Refer to Number of "A" on a table of item (10).)
7. **Consult Factory** : No need to choose and assign. Identification number for designer and factory usage.



4. Complete Z₀=50Ω Coaxial Spring Probe IC Socket

Tatsumi Watabe
S.E.R. Corporation : Managing Director

1. Overview

IC Test Socket for SHF best performance, SER has realized Complete 50Ω Characteristic Impedance Coaxial Probe to use for FBGA and CSP Testing. Complete Z₀ Coaxial Probe, the concept is to do careful design for every portion detail on plungers, barrel, dielectric in coaxial to fit Z₀=50Ω and consider keeping totally stable GND design for PCB, IC and Socket GND. The Complete Z₀ Coaxial Probe has been confirmed the frequency performance exceeded 20GHz on Transmission Performance. The socket is available for 1.0, 0.8 and 0.5mm pitch.

The base socket is composed of 3 featured concept. (Photo.1)

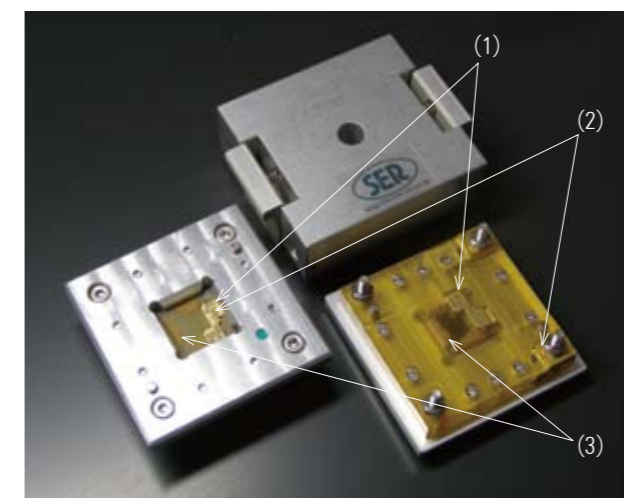

Photo.1 Complete Z₀=50Ω Coaxial Spring probe IC Socket (0.5mm pitch)

- (1) Complete Coaxial Spring Probe Contacts.
- (2) Socket GND organize block.
- (3) Regular composed Spring Probe block.

Best performance was brought from a combination of combining (1) and (2). It was confirmed by S parameter loop measurement by specialized board and Network Analyzer using like Fig. 3. And total cost saving comes from composing of (3).

2. Complete Zo Coaxial Probe (1).

Because Characteristic impedance is decided by the equation.

$$Z_0 = 138 / \sqrt{\epsilon} \times \log(D/d)$$

All Coaxial probe portion from PCB side (bottom) to IC terminal side (top) is designed to fit in $Z_0=50\Omega$ by choosing and adjust Dielectric (ϵ) and diameter of plunger and barrel. This example : Coaxial GND diameter is 0.9mm for 1.0mm matrix pitch and 0.41mm for 0.5mm matrix pitch.

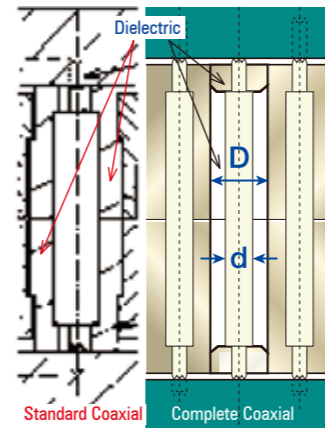

Fig. 1 Coaxial probe

3. Core Probe for Coaxial Probe (1).

1.0mm (MD102-00) : diameters Barrel 0.40mm Plunger 0.20mm, 0.5mm (MD138-00) : diameters Barrel 0.18mm, Plunger 0.18mm are used. (Fig. 2) And deferent dielectric are used for plunger portion and barrel portion individually.

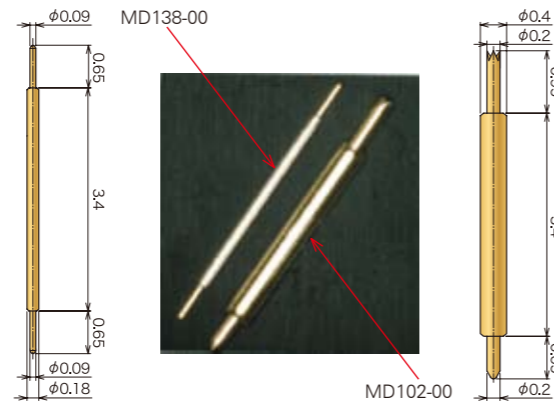

Fig. 2 Coaxial core probe.

4. Coaxial GND is equate PCB GND (2).

It is distinguished high frequency GND (analog GND on this IC socket) to other GND. Metal base is used for the Coaxial GND partially as Socket GND organized to PCB GND. Then IC GND was equalized to PCB GND by this composing.

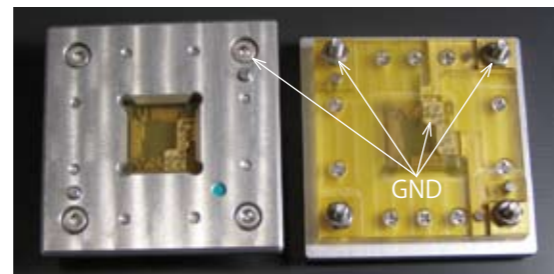

Photo. 2 Socket GND organize

5. Measurement Condition.

High frequency signal source through a Pico Probe touching to the specialized board (characterized to $Z_0=50\Omega$) holding Probe or Coaxial Probe be assembled as same condition of IC base socket. And the signal return to Network Analyzer by loop test condition. (Fig. 3)

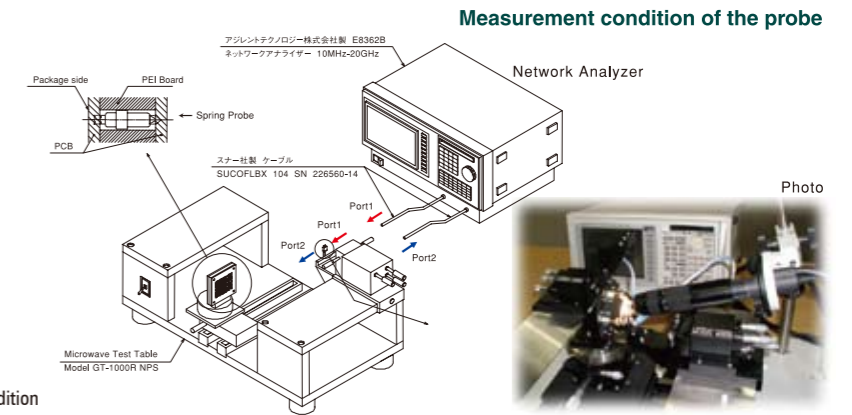

Fig. 3 Measurement condition

6. Probe S21 Performance.

A probe is designed with flung or resistive belting on its surface has a transmission performance 5 through 7 GHz only. (Fig. 4) It is not restricted by probe length like Fig 4. For achieving max. frequency performance, a core probe for coaxial must be more efficient design for SHF performance.

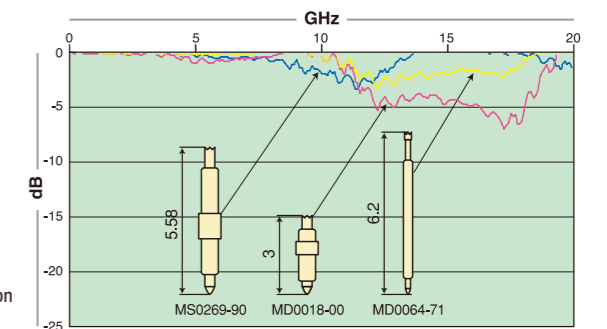

Fig. 4 Probe performance restriction

7. Complete Zo=50Ω Coaxial Probe Performance.

20 GHz transmission performance was measured. A conditioning of complete Zo coaxial technique with, Socket GND equate technique brought this achievement for both of 1.0 mm and 0.5 mm coaxial probe socket by using MD102-00 and MD138-00 core probe. (Fig. 5)

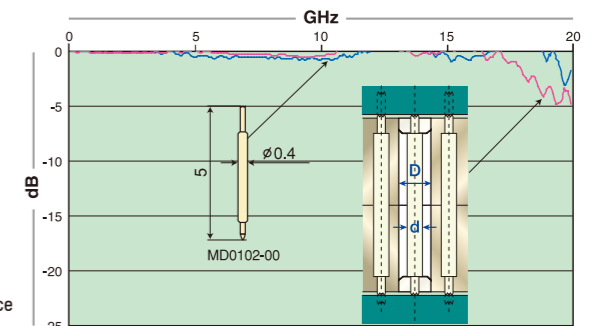

Fig. 5 Complete Coaxial Probe Performance

Best design concept for IC Socket's Probe and GND location is required to be best fitting to IC contact terminal matrix. I think it will be needed more cooperated relationship enhancement between 'socket makers' and user 'IC users' together.

5. Equivalent-circuit Model on $Z_0=50\Omega$ Complete Coaxial Spring Probe

Makoto Kawamura
S.E.R. Corporation

Description

It is indispensable matter to give performance simulation on PCB patterning by using SPICE simulator or like HSPICE prior to designing circuit wiring for PCB mounting LSI on high speed/frequency signal band width of SHF (Super-high Frequency) application. In order to meet with the demand of simulation for PCB circuit patterning and wiring including LSI and IC socket, this report found a parametric value of equivalent circuit composed by passive element focused on 10 GHz band width for a coaxial spring probe "SER P/N: MD0102-00 be used" being used for 1.0mm pitch Complete $Z_0=50\Omega$ Coaxial Probe Socket, by measuring S Parameter using Network Analyzer.

1. S Parameter Measurement

As shown on Fig.1, the coaxial structured probe pins are measured with a loop measurement and S parameter by using the Agilent Technologies' PNA Series Network Analyzer. S Parameter of Complete $Z_0=50\Omega$ Coaxial Probe is measured as same structure of IC socket using GGB Pico Probe being adjustable to touch to measuring pad location as a composition of test instruments known performance.

Fig. 1 S Parameter Measurement

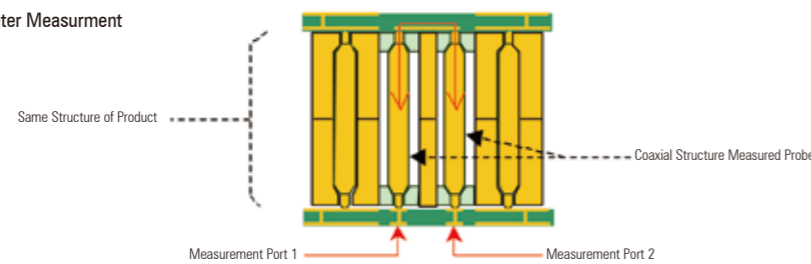

2. Optimization for Equivalent Circuit

S Parameter data measured by a method like Fig.1 is applied to circuit simulation software ADS (Agilent) and

introduce an optimization of passive component element in equivalent circuit shown Fig. 2. The equivalent circuit of Fig. 2 is configured as symmetrically same 2 parts of spring probe component port.

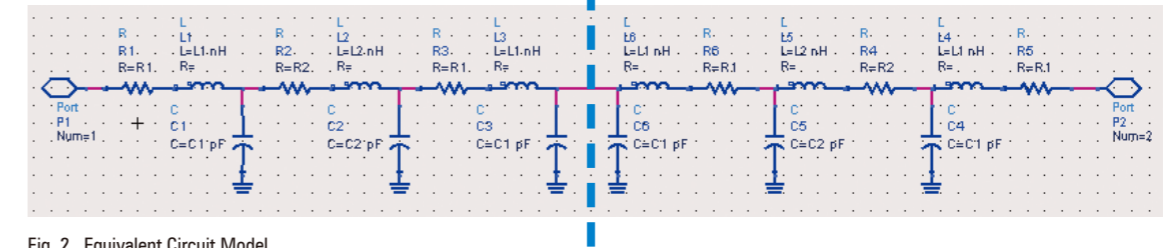

Fig. 2 Equivalent Circuit Model

2-1. Result on Optimization.

Table. 1 is the circuit elements value optimized by ADS using actual measurement data and equivalent circuit above. Also Fitting results are shown on Fig. 3 as below

C1 (=C4)	C2 (=C5)	C3 (=C6)	R1 (=R5)	R2 (=R4)	R3 (=R6)	L1 (=L4)	L2 (=L5)	L3 (=L6)
0.364pF	0.001pF	0.364pF	0.005Ω	0.01Ω	0.005Ω	0.317nH	0.598nH	0.317nH

Table. 1 Equivalent Circuit Element

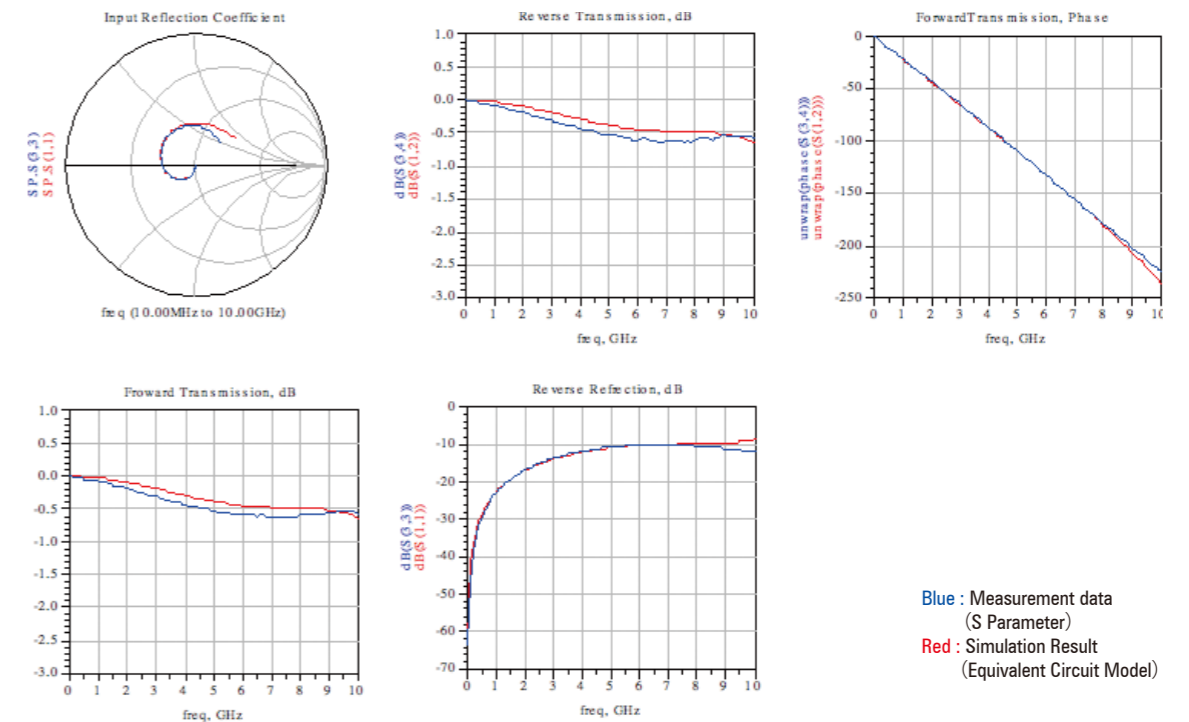
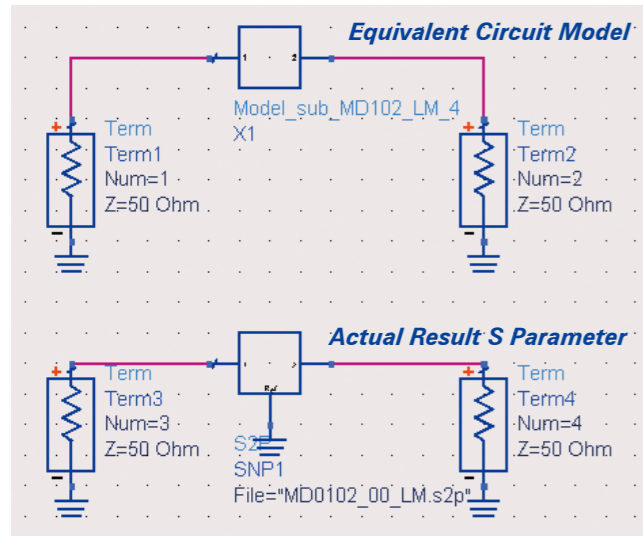

Fig. 3 Result of Optimization with Simulation Software



Simulation Circuit

2-2. Simulation on Time Domain

Time domain simulations results (TDR/TDT) based on the parameter optimized by ADS are shown on below. Rise time of input pulse was taken 75pico seconds being equivalent to 10GHz.

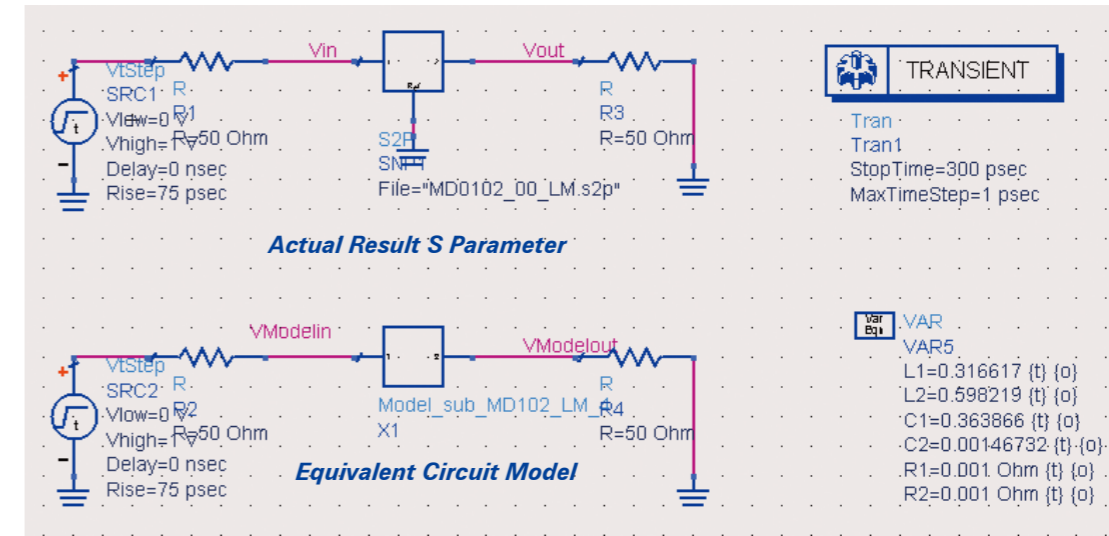
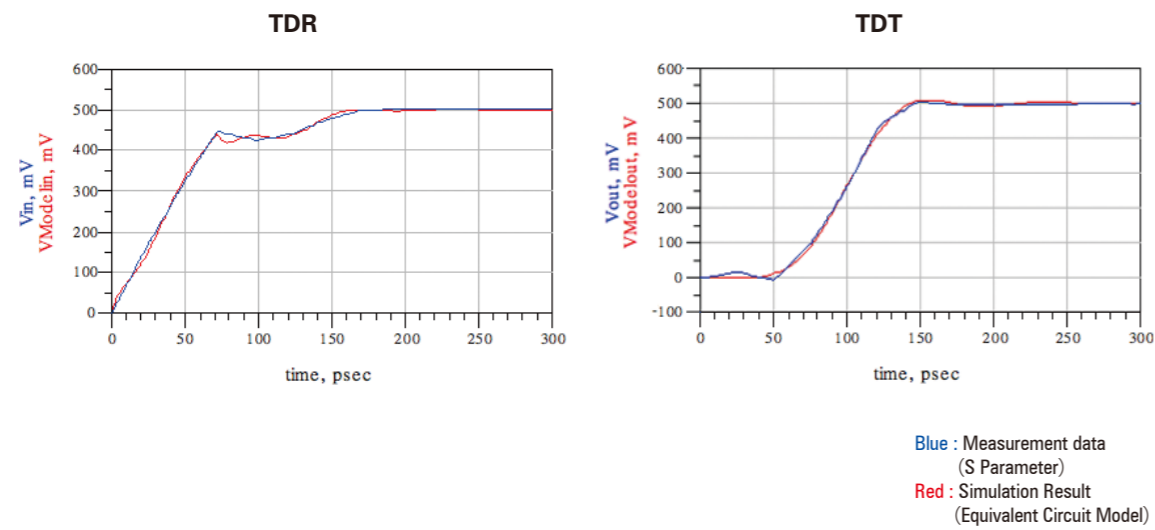

Time Domain Simulation Circuit

3. Consideration

Performance and characteristics on this measurement for pair of complete coaxial probe on Fig1 were -0.5dB through -0.6dB for the worst at the frequency around 10GHz on Transmission Performance. Effectiveness of a complete coaxial structure socket compare with non-coaxial IC socket, even the same contact probe pins are used, are appeared about 1dB "@10GHz" in transit characteristic and about -4dB "@10GHz" in reflection characteristic deference.

Based on the compared result of the actual S parameter, the simulation optimized circuit number is able to obtain maximum 0.2dB difference with the actual data of transient characteristic. It is meaning of getting proper correlation including a phase.

ELECTRONICS PARTS



**CUSTOMIZED
SOCKETS & CONNECTORS**

S.E.R. CORPORATION

HEAD OFFICE STAR BLD., 1-14-8, KITASHINAGAWA, SHINAGAWA-KU, TOKYO, JAPAN 140-0001
TEL +81-3-5796-0330 FAX +81-3-5796-3210
E-mail : ser@ser.co.jp

OSAKA OFFICE 10F-A SHIN-OSAKA GLAND BLD., 2-14-14, MIYAHARA, YODOGAWA-KU, OSAKA CITY, OSAKA, JAPAN 532-0003
TEL +81-6-6398-6008 FAX +81-6-6398-6009
E-mail : ser-osaka@ser.co.jp

S . E . R . U S A S.E.R. ELECTRONICS INC.
3478 BUSKIRK AVE, SUITE 1020, PLEASANT HILL, CA94523 U.S.A.
TEL +1-925-746-7166 FAX +1-925-746-7153
E-mail mtaira@serusa.com URL <http://www.serusa.com>

S.E.R. TAIWAN S.E.R. TAIWAN CORPORATION
5F NO.9 LANE126 HSUEH-FU ROAD SEC.1,TU-CHENG CITY,TAIPEI HSIEN,TAIWAN
TEL +886-2-2273-8792 FAX +886-2-2273-8790
E-mail ser.taiwan@msa.hinet.net